



yellobrik®

yellobrik®

Quick Reference

Technical Specifications

Ethernet	2x Ethernet ports, RJ 45 Connectors. 10 BaseTUTP category 3,4 or 5 cable up to 328ft/100m (2 pairs) 100 BaseTXUTP category 5 cable up to 328ft/100m (2 pairs) 1000 BaseTXUTP category 5 cable up to 328ft/100m (4 pairs)
	Auto detect bit rate (10/100/1000), or force to 10Mbit/s for each port
	Automatic crossover detection or force manually for each port
	Port speed / activity LED indication (next to Ethernet port)
Fiber Optic	1x 1GbE Simplex Fiber Transceiver (LC/PC connector) WDM using 1310nm and 1550 wavelenghts Optical budget: 18dB Max. Distance: 10km(6.2 miles - Singlemode)* TX and RX active LEDs on side of module
Power	+12V DC @ 1.7W nominal (without SFP) 7 - 22V DC input range Power LED on side of module

*distances are an approximation depending on fibers used and quality of physical connections.

We are constantly adding more yellobrik modules.
Please visit our website for the latest product updates.

www.lynx-technik.com

This device complies with part 15 of the FCC Rules. Operation is subject to the following two conditions: (1) This device may not cause harmful interference, and (2) this device must accept any interference received, including interference that may cause undesired operation.

LYNXTechnik | Broadcast Television Equipment

OBD 1514 E

Ethernet to Fiber Transceiver (switch)

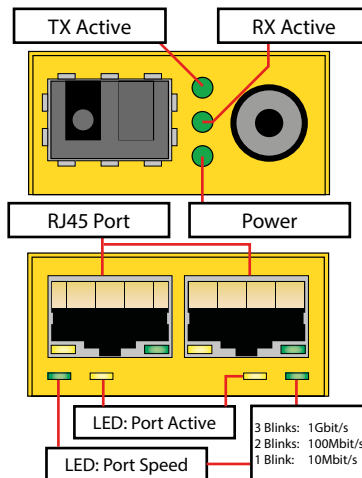
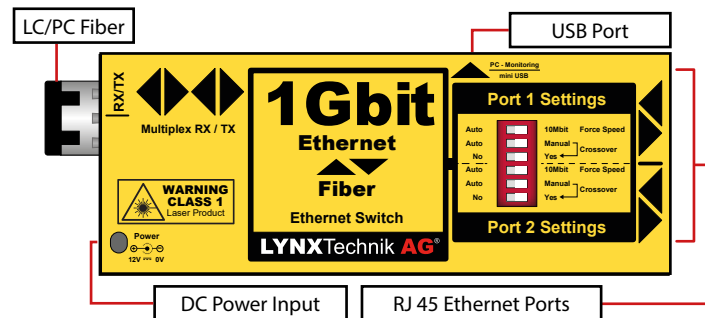

WARNING



LASER RADIATION
Do not view directly with
optical instruments

CLASS 1M LASER PRODUCT

WARNING: Module laser is active
as soon as power is connected,
regardless of LED indication

Connections

The module operates as a 3 port ethernet switch with 2 standard RJ45 electrical ethernet ports and an SFP port for single fiber connectors.



If not connected, use the included dust plug to protect the SFPs optical connection from dust and eyes from the laser light.

Operation

The module maintains a constant fiber communication speed regardless of the speed of the 2 electrical ports. The electrical ethernet ports can be configured independently using the module dip switch if required. This facilitates the use with older legacy electrical networks.

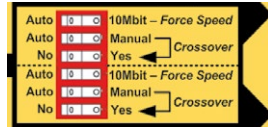

The electrical port speeds can be set to automatic mode (10/100/1000 Mbit/s) or forced 10Mbit/s if required. It is also possible to configure automatic or manual crossover for the electrical ports (forced manual crossover is sometimes needed for older networks).

Note: TX LED is continuously ON as soon as an SFP is inserted and the device is powered on. The purpose is to protect eyes and other optical instrument, as the SFP laser is active.

Power Lead Strain Relief

The module has a small hole in the case which is located above the power connection. This prevents the power lead being accidentally pulled out. Use the supplied tie-wrap and secure the lead as shown.

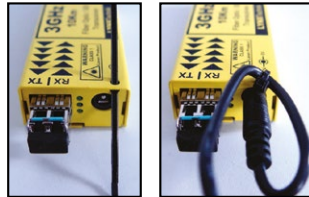

Power

The module requires a clean 12V DC (7-22V DC) power source. An LED is provided to confirm power is connected. A 12V DC power supply is included with the module. Power consumption information can be found in the technical specifications table.

Optional Mounting Solutions

The optional RFR 1001 mounting bracket can be used to mount the module on any surface or on 19" rack rails.



The optional rack mount can be used to permanently mount up to 14 yellobrik modules. In addition, the RFR 1200 can provide full power redundancy for all mounted yellobriks.



USB Connection

The USB interface of the module is used for monitoring and firmware updates. To update a yellobrik, power it on and connect it to a PC or Mac running LYNX control software (yelloGUI or LynxCentraal) with the provided USB cable.

You will be notified if a new firmware is available.



Online Product Page

For additional information on the device visit our website via the QR code to the right. This website shows the most recent datasheets, quick reference guides and more.

If you encounter issues or have questions regarding the device please visit our support section.

